

The magnetic field between the poles of the electromagnet in Fig. 29.5 is uniform at any time, but its magnitude is increasing at the rate of  $0.020 \text{ T/s}$ . The area of the conducting loop in the field is  $120 \text{ cm}^2$ , and the total circuit resistance, including the

meter, is  $5.0 \ \Omega$ . (a) Find the induced emf and the induced current in the circuit. (b) If the loop is replaced by one made of an insulator, what effect does this have on the induced emf and induced current?

### 29.5 A stationary conducting loop in an increasing magnetic field

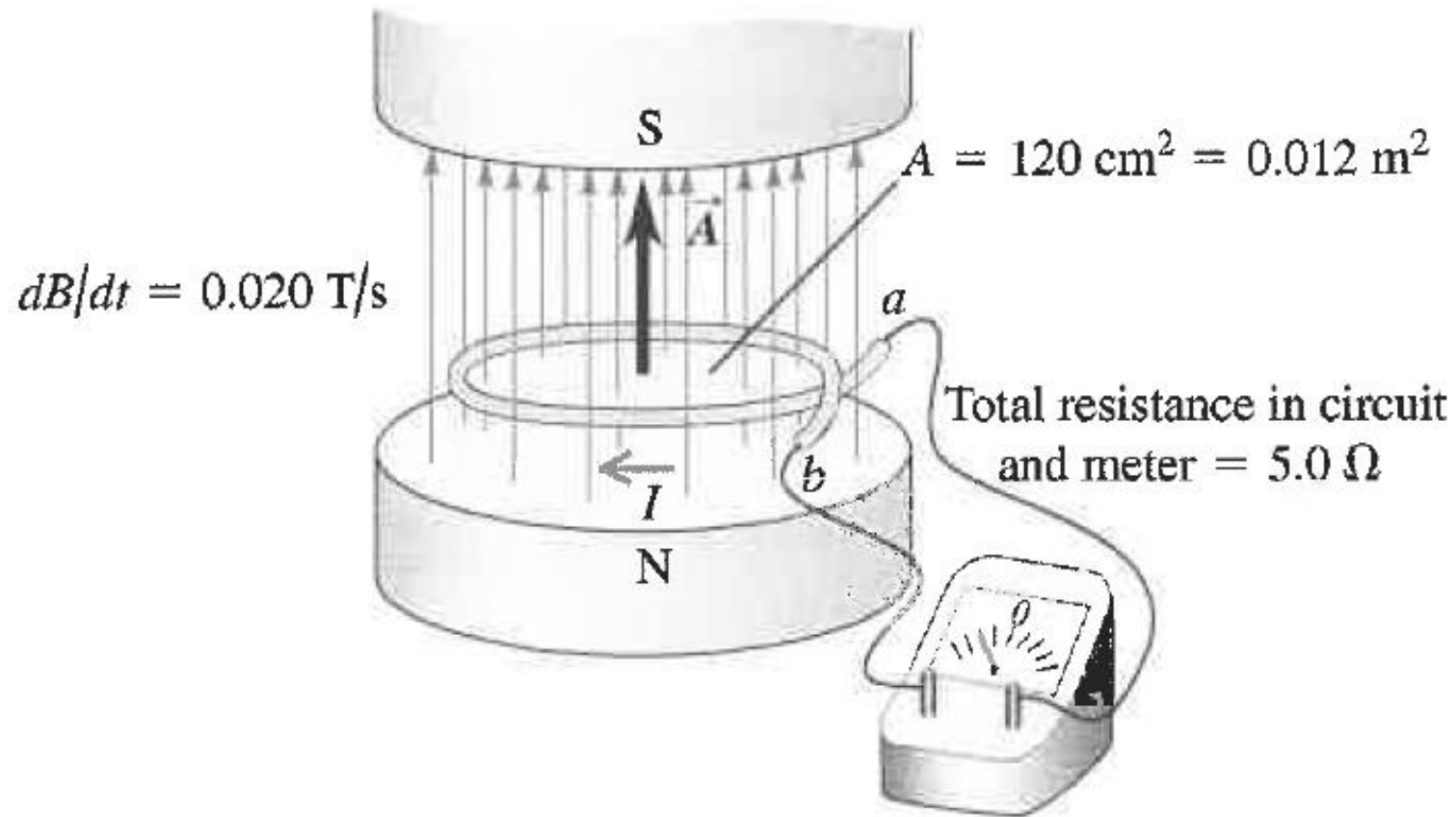

A 500-loop circular wire coil with radius 4.00 cm is placed between the poles of a large electromagnet. The magnetic field is uniform and makes an angle of  $60^\circ$  with the plane of the coil; it decreases at  $0.200 \text{ T/s}$ . What are the magnitude and direction of the induced emf?

**29.7** Our sketch for this problem.

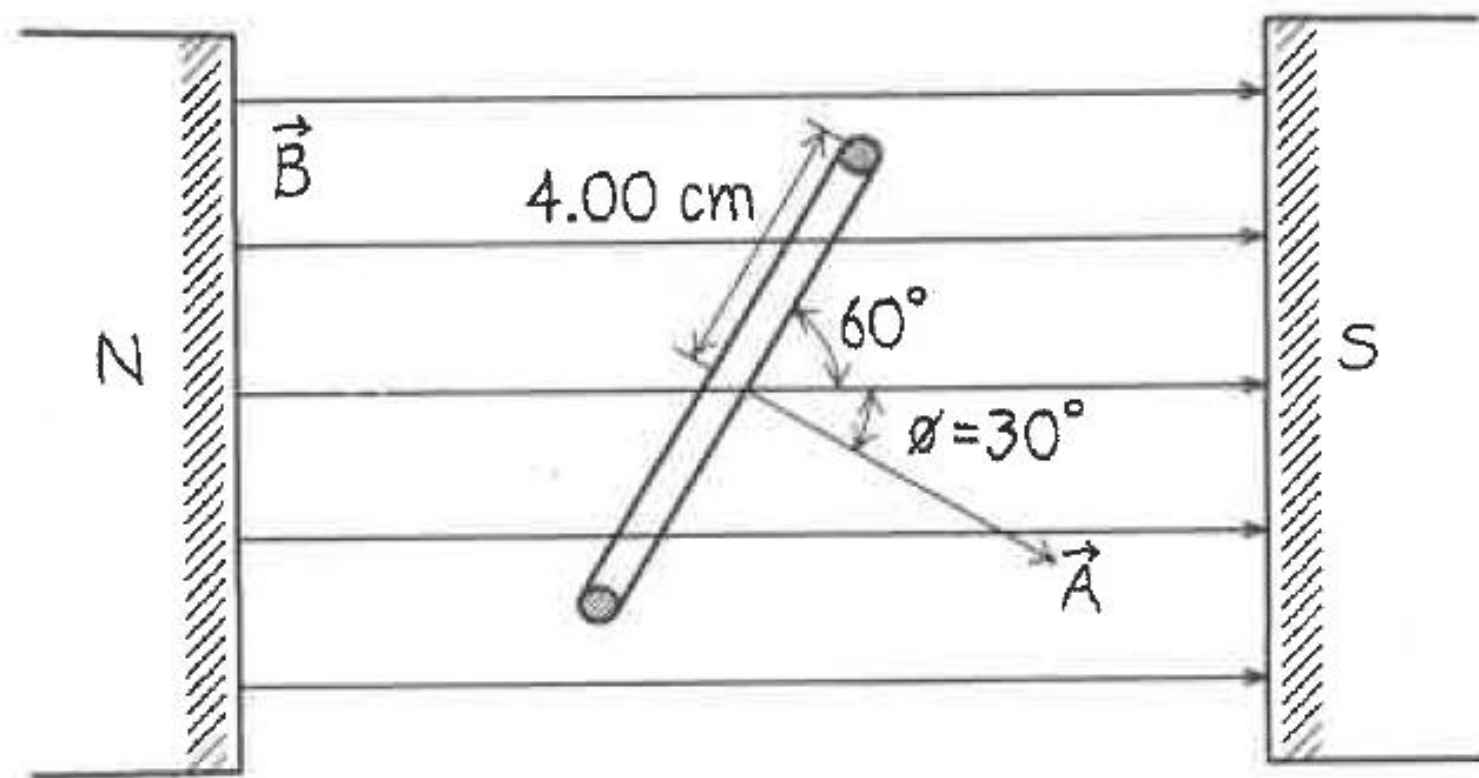
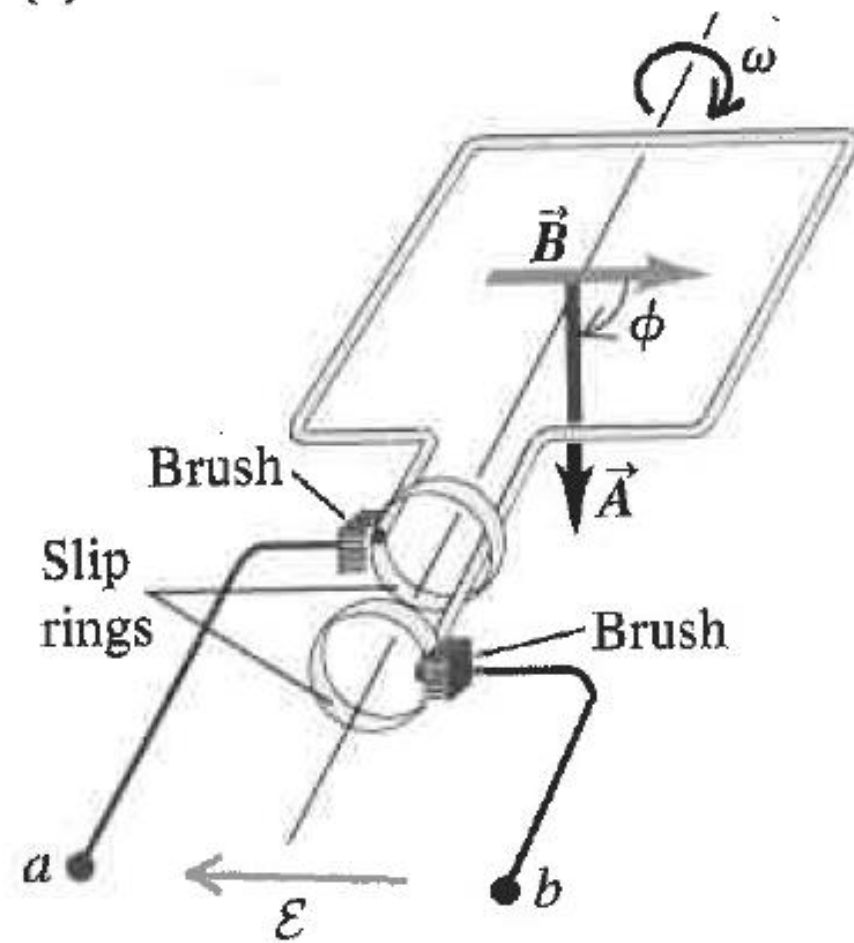

Figure 29.8a shows a simple *alternator*, a device that generates an emf. A rectangular loop is rotated with constant angular speed  $\omega$  about the axis shown. The magnetic field  $\vec{B}$  is uniform and constant. At time  $t = 0$ ,  $\phi = 0$ . Determine the induced emf.

(a)



(b)

Loop (seen end-on)



Flux decreasing most rapidly, largest positive emf.

Flux increasing most rapidly, largest negative emf.

Flux at its most negative value, emf is zero.

Flux at its most positive value, emf is zero.

$$\mathcal{E} = -d\Phi_B/dt$$

$\mathcal{E}, \Phi_B$

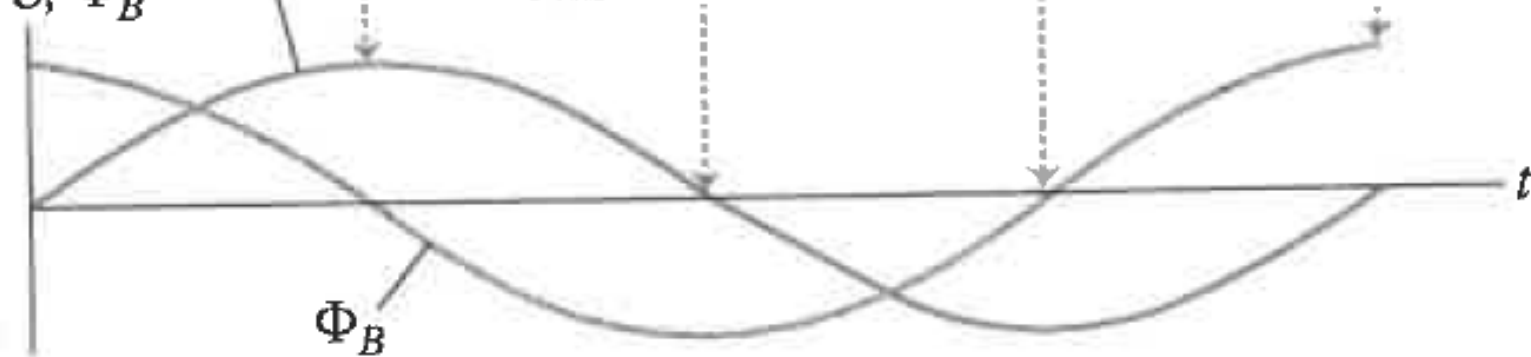

Figure 29.16 shows a conducting disk with radius  $R$  that lies in the  $xy$ -plane and rotates with constant angular velocity  $\omega$  about the  $z$ -axis. The disk is in a uniform, constant  $\vec{B}$  field in the  $z$ -direction. Find the induced emf between the center and the rim of the disk.

