

1. Consider the infinitely long chain of resistors shown in the figure. What is the resistance between terminals a and b ?

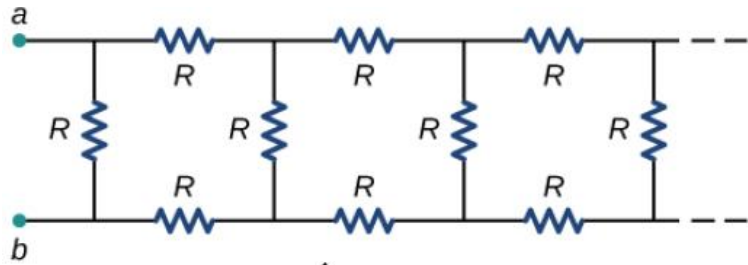

2. Consider the circuit below. The capacitor has a capacitance of 10 mF. The switch is closed and after a long time the capacitor is fully charged. (a) What is the current through each resistor a long time after the switch is closed? (b) What is the voltage across each resistor a long time after the switch is closed? (c) What is the voltage across the capacitor a long time after the switch is closed? (d) What is the charge on the capacitor a long time after the switch is closed? (e) The switch is then opened. The capacitor discharges through the resistors. How long from the time before the current drops to one fifth of the initial value?

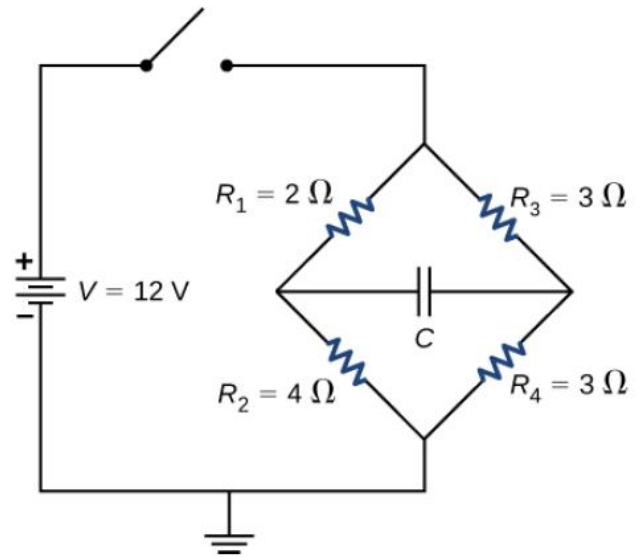

3.

Q27.12 Each of the lettered points at the corners of the cube in Fig. Q27.12 represents a positive charge q moving with a velocity of magnitude v in the direction indicated. The region in the figure is in a uniform magnetic field \vec{B} , parallel to the x -axis and directed toward the right. Which charges experience a force due to \vec{B} ? What is the direction of the force on each charge?

Figure **Q27.12**

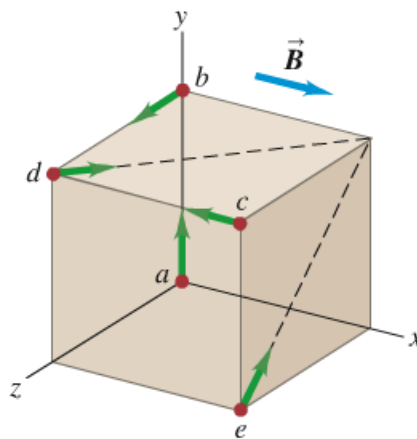

I have done this one in class. Repeat with new field: $B = -B_0 \hat{j} + (B_0)/2 \hat{k}$

4.

27.7 •• CP A particle with charge $7.80 \mu\text{C}$ is moving with velocity $\vec{v} = -(3.80 \times 10^3 \text{ m/s})\hat{j}$. The magnetic force on the particle is measured to be $\vec{F} = +(7.60 \times 10^{-3} \text{ N})\hat{i} - (5.20 \times 10^{-3} \text{ N})\hat{k}$. (a) Calculate all the components of the magnetic field you can from this information. (b) Are there components of the magnetic field that are not determined by the measurement of the force? Explain. (c) Calculate the scalar product $\vec{B} \cdot \vec{F}$. What is the angle between \vec{B} and \vec{F} ?