

Part I. Questions 1-10. 8 points each. Multiple choice: For **full credit**, circle only the **correct** answer. For **half credit**, circle the **correct** answer and **one incorrect** answer. For  $\frac{1}{4}$  **credit**, circle the **correct** answer and **two incorrect** answers.

1. A positively-charged ring lies in the  $xy$  plane, as shown at the right. Along which axis does the electric field point at point P?

- a. the positive  $z$  axis
- b. the negative  $z$  axis
- c. the positive  $y$  axis
- d. the negative  $y$  axis
- e. the positive  $x$  axis
- f. the negative  $x$  axis
- g. none of the above

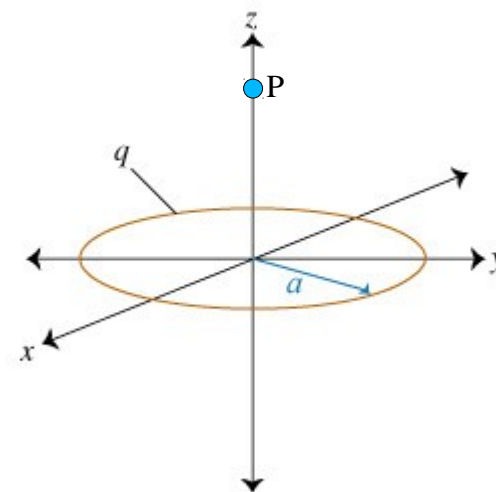

2. Two charged particles repel each other with a force  $F$ . If the charge of both particles is doubled and the distance between them is also doubled, then the force between them will be

- a.  $\frac{1}{4} F$
- b.  $\frac{1}{2} F$
- c.  $F$
- d.  $2 F$
- e.  $4 F$

3. A cube of volume  $L^3$  is oriented with its right and left faces perpendicular to a uniform electric field  $E$  that points in the positive  $x$  direction. If each side of the cube is increased from length  $L$  to  $2L$ , the electric flux through the cube will

- a. increase by a factor of 2.
- b. increase by a factor of 8.
- c. remain the same.
- d. decrease by a factor of 2.
- e. decrease by a factor of 8.

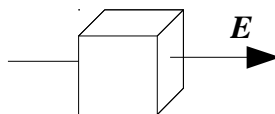

4. A negatively-charged conductor has a cavity in its interior. Volume B is the conducting material, whereas C represents the region outside the conductor. Placing a positive point charge inside the cavity would

- a. increase the electric field in B and C.
- b. increase the electric field in B, but decrease the electric field in C.
- c. increase the electric field in B, but not affect the electric field in C.
- d. not affect the electric field in B, but increase the electric field in C.
- e. not affect the electric field in B nor in C.
- f. not enough information is given in this problem.

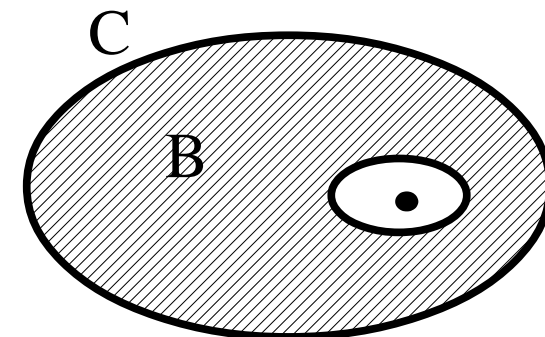

5. A lithium nucleus with a charge of  $+3q$  and a mass of  $7m$ , and an alpha particle with a charge of  $+2q$  and a mass of  $4m$ , are at rest.

They could be accelerated to the same kinetic energy by

- a. accelerating them through the same electrical potential difference.
- b. accelerating the alpha particle through  $V$  volts and the lithium nucleus through  $2/3 V$  volts.
- c. accelerating the alpha particle through  $V$  volts and the lithium nucleus through  $7/4 V$  volts.
- d. accelerating the alpha particle through  $V$  volts and the lithium nucleus through  $7/6 V$  volts.
- e. none of these procedures.

6. The direction that best represents the direction of the electric field at point  $x$  on the  $200 V$  equipotential line is

- a. 1
- b. 2
- c. 3
- d. 4
- e. none of these is correct

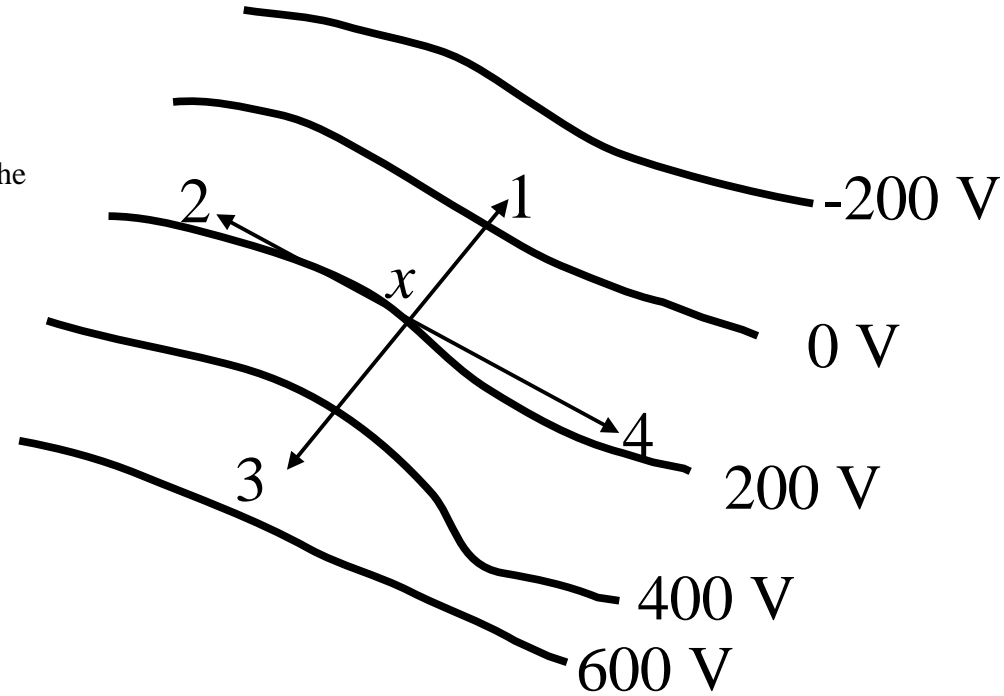

7. An air-filled parallel plate capacitor is connected to a battery and allowed to charge up. When a slab of dielectric material is placed between the plates of the capacitor, while the battery is still connected to the capacitor, the

- a. energy stored in the capacitor decreases.
- b. voltage across the capacitor increases.
- c. charge on the capacitor increases.
- d. charge on the capacitor decreases.
- e. none of these is true.

8. You want to use three 3pF capacitors in a circuit. Which configuration would yield an equivalent capacitance of 2 pF between points  $x$  and  $y$ ?

- a. a
- b. b
- c. c
- d. d
- e. none of these is correct

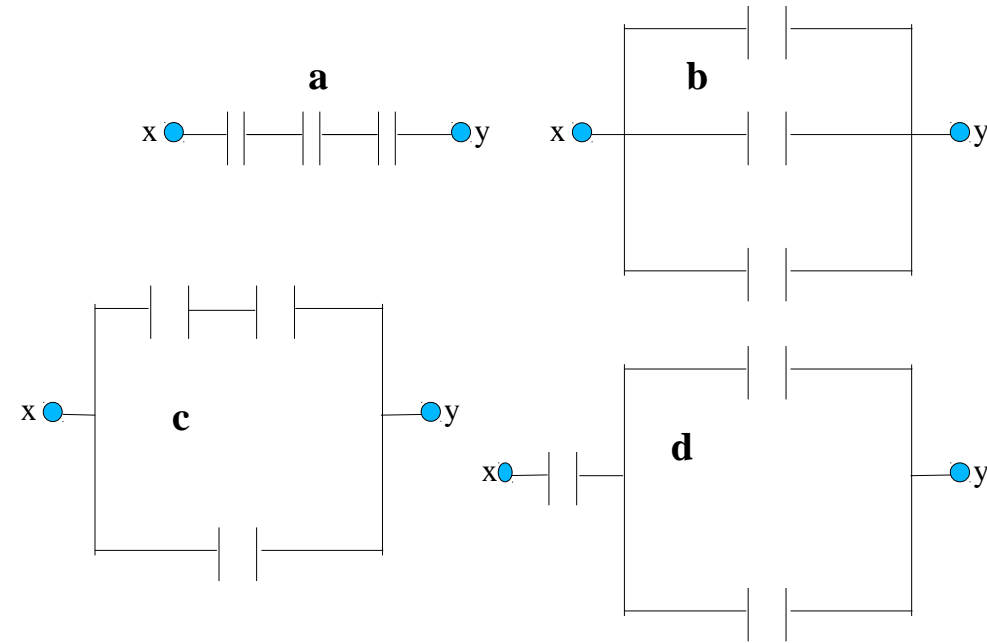

9. When there is a net static charge present on a perfect conductor, and no other charges are present,

- a. the charge will be uniformly distributed over the outside of the conductor.
- b. every point throughout the entire conductor will be at zero potential.
- c. every point throughout the entire conductor will be at a constant potential, but not necessarily at zero potential.
- d. the electric field inside the conductor need not be zero if the conductor is hollow.
- e. the surface charge density will be greatest where the conductor is flat and smallest where there are sharp protuberances or points.

10. If the potential difference of a capacitor is reduced by one-half, the energy stored in that capacitor is

- a. decreased by a factor of 2.
- b. decreased by a factor of 4.
- c. increased by a factor of 2.
- d. increased by a factor of 4.
- e. not changed.

Part II. Short answer/sketch. Answer questions 11-13 as completely as possible. **Show your work to earn partial credit!**

**11.** (23 points)

Electric charge is distributed uniformly along each side of a square. Two adjacent sides have positive charge with total charge  $+Q$  on each, and the other two adjacent sides each have total charge  $-Q$ . Each side of the square has length  $a$ .

Recall that  $E(x)=kQ/x/(x^2+l^2)^{1/2}$  for a line of charge  $Q$  and length  $2l$ .

a. In which direction does the electric field point at the origin  $(x=0,y=0)$ ?

b. What are the magnitudes of the  $x$ ,  $y$ , and  $z$  components of the electric field at the origin? ( $z$  points out of the page)

c. Repeat part a if all four sides each have charge  $+Q$ .

d. Repeat part b if all four sides each have charge  $+Q$ .

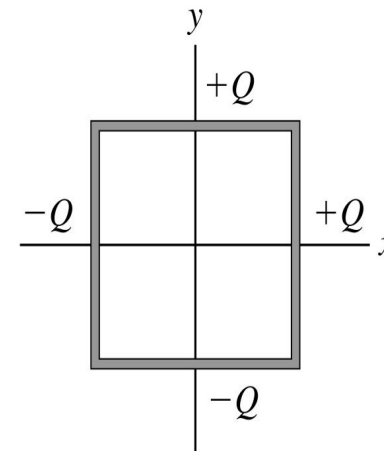

12. (27 points)

A solid metal sphere with radius  $a$  carries positive charge  $+Q$ . It is concentric with a thick metal shell of inner radius  $b$ , outer radius  $c$ , and charge  $-3Q$ . Both the sphere and the shell are concentric with a thin insulating shell of radius  $d$  and charge  $+7Q$ .

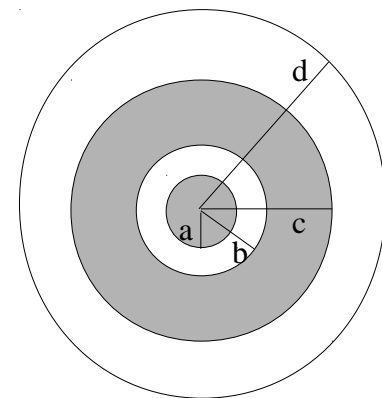

a. Draw representative electric field lines for all regions in the figure to the right.

b. Describe in words how the charge is distributed for the metal sphere.

c. Describe in words how the charge is distributed for the metal shell. Carefully explain how much is on the inner surface, how much is on the outer surface, and how much is distributed between the inner and outer surfaces.

d. Compute the electric field and potential for each region (assume  $V=0$  at  $\infty$ ):

$E(r < a) =$

$V(r < a) =$

$E(a < r < b) =$

$V(a < r < b) =$

$E(b < r < c) =$

$V(b < r < c) =$

$E(c < r < d) =$

$V(c < r < d) =$

$E(r > d) =$

$V(r > d) =$

e. Sketch the electric field as a function of  $r$ .

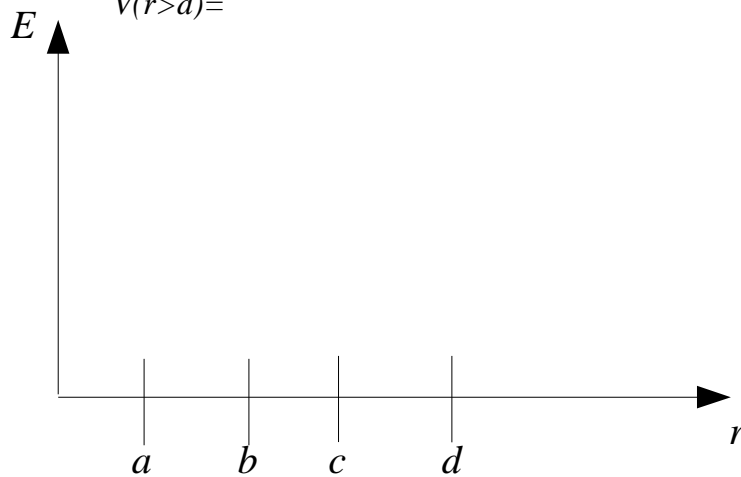

**13. (25 points)**

Two parallel-plate capacitors and a battery form a circuit. Each capacitor has plate area  $A$  and plate separation  $d$ . The battery provides a potential difference  $\Delta V$ .

In **Phase I** the upper capacitor is filled with a dielectric material of dielectric constant  $K$ .

a. What is the capacitance, charge, and energy stored for the upper capacitor?  
 $C_{\text{upper}} =$                        $Q_{\text{upper}} =$                        $U_{\text{upper}} =$

b. What is the capacitance, charge, and energy stored for the lower capacitor?  
 $C_{\text{lower}} =$                        $Q_{\text{lower}} =$                        $U_{\text{lower}} =$

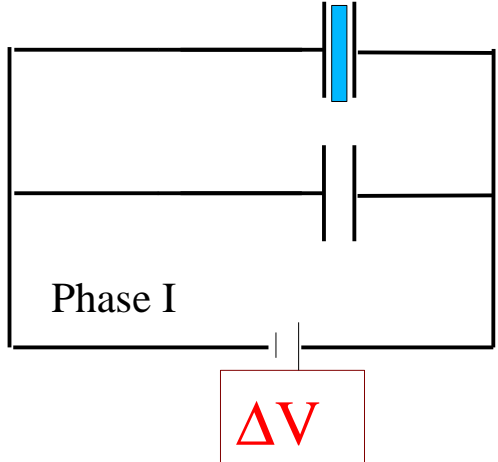

In **Phase II** the dielectric material is pulled halfway out of the upper capacitor.

c. What is the capacitance, charge, and energy stored for the upper capacitor?  
 $C_{\text{upper}} =$                        $Q_{\text{upper}} =$                        $U_{\text{upper}} =$

d. Does the charge on the lower capacitor change from Phase I to Phase II?

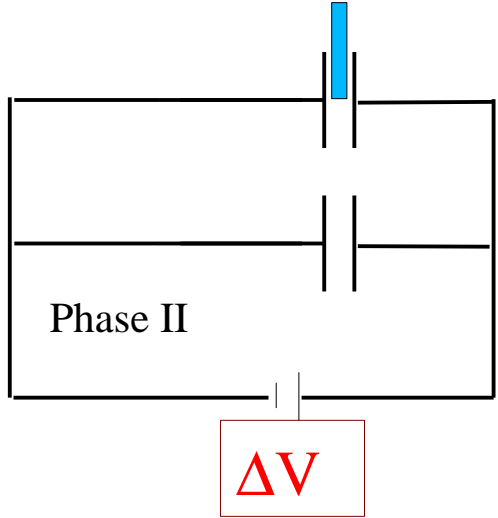

In **Phase III** the battery is first disconnected, and then the dielectric is pulled completely out of the upper capacitor.

e. What is the capacitance, charge, and energy stored for the upper capacitor?  
 $C_{\text{upper}} =$                        $Q_{\text{upper}} =$                        $U_{\text{upper}} =$

f. How much work is done by the external agent in pulling the dielectric completely out of the capacitor?  
 $W =$

