

Includes
Teacher's Notes
and
Typical
Experiment Results



**Instruction Manual and
Experiment Guide for the
PASCO scientific
Model TD-8553/8554A/8555**

012-04695D

03/99

THERMAL RADIATION SYSTEM

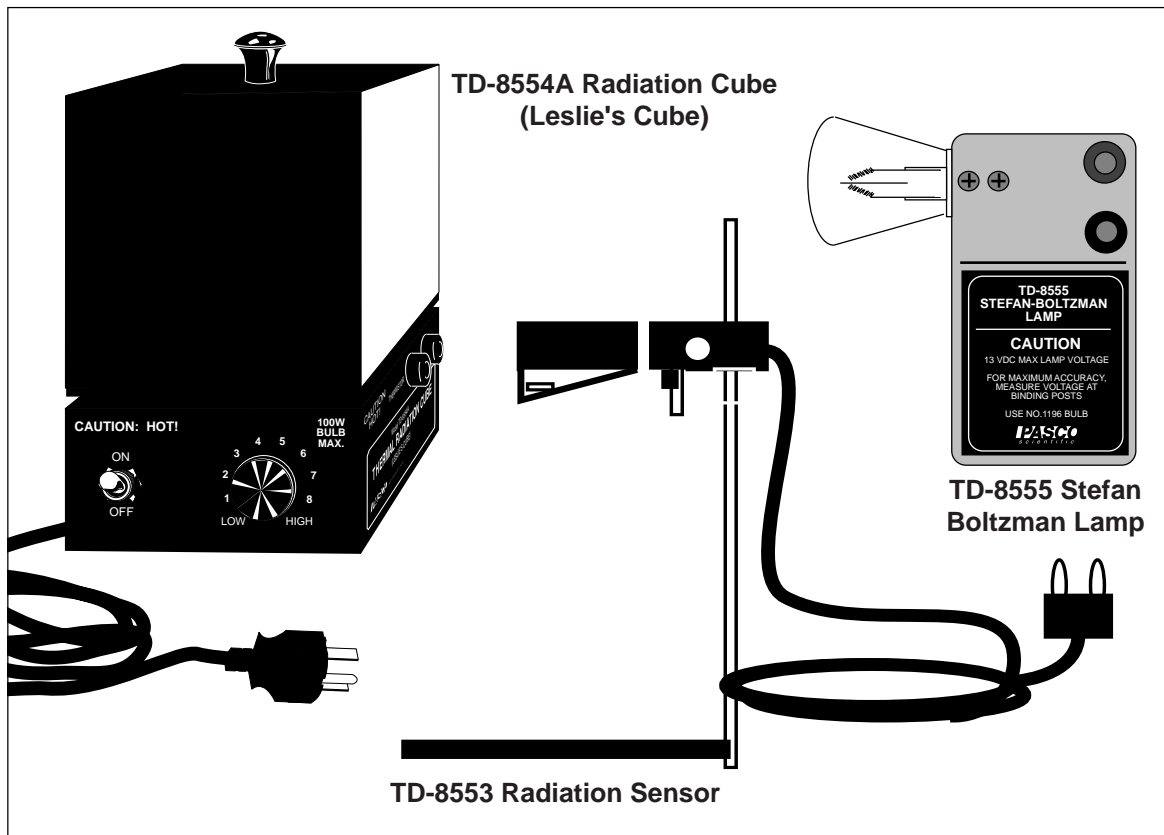

© 1988 PASCO scientific

\$5.00

PASCO[®]
scientific

10101 Foothills Blvd. • Roseville, CA 95747-7100
Phone (916) 786-3800 • FAX (916) 786-8905 • www.pasco.com

better

ways to

teach science



The lightning flash with arrowhead, within an equilateral triangle, is intended to alert the user of the presence of uninsulated "dangerous voltage" within the product's enclosure that may be of sufficient magnitude to constitute a risk of electric shock to persons.



CAUTION:
TO PREVENT THE RISK OF
ELECTRIC SHOCK, DO NOT
REMOVE BACK COVER. NO USER
SERVICEABLE PARTS INSIDE.
REFER SERVICING TO QUALIFIED
SERVICE PERSONNEL.



The exclamation point within an equilateral triangle is intended to alert the user of the presence of important operating and maintenance (servicing) instructions in the literature accompanying the appliance.

Table of Contents

Section	Page
Copyright and Warranty, Equipment Return	ii
Introduction	1
Radiation Sensor	1
Thermal Radiation Cube (Leslie's Cube)	2
Stefan-Boltzmann Lamp	3
Experiments:	
Experiment 1: Introduction to Thermal Radiation	5
Experiment 2: Inverse Square Law	9
Experiment 3: Stefan-Boltzmann Law (high temperature)	13
Experiment 4: Stefan-Boltzmann Law (low temperature)	17
Teacher's Guide	19
Technical Support	Inside Back Cover

Copyright, Warranty, and Equipment Return

Please—Feel free to duplicate this manual subject to the copyright restrictions below.

Copyright Notice

The PASCO scientific Model TD 8553/8554A/8555 Thermal Radiation System manual is copyrighted and all rights reserved. However, permission is granted to non-profit educational institutions for reproduction of any part of the manual providing the reproductions are used only for their laboratories and are not sold for profit. Reproduction under any other circumstances, without the written consent of PASCO scientific, is prohibited.

Limited Warranty

PASCO scientific warrants the product to be free from defects in materials and workmanship for a period of one year from the date of shipment to the customer. PASCO will repair or replace at its option any part of the product which is deemed to be defective in material or workmanship. The warranty does not cover damage to the product caused by abuse or improper use. Determination of whether a product failure is the result of a manufacturing defect or improper use by the customer shall be made solely by PASCO scientific. Responsibility for the return of equipment for warranty repair belongs to the customer. Equipment must be properly packed to prevent damage and shipped postage or freight prepaid. (Damage caused by improper packing of the equipment for return shipment will not be covered by the warranty.) Shipping costs for returning the equipment after repair will be paid by PASCO scientific.

Credits

This manual authored by: Bruce Lee

Teacher's guide written by: Eric Ayres

Equipment Return

Should the product have to be returned to PASCO scientific for any reason, notify PASCO scientific by letter, phone, or fax BEFORE returning the product. Upon notification, the return authorization and shipping instructions will be promptly issued.

► **NOTE: NO EQUIPMENT WILL BE ACCEPTED FOR RETURN WITHOUT AN AUTHORIZATION FROM PASCO.**

When returning equipment for repair, the units must be packed properly. Carriers will not accept responsibility for damage caused by improper packing. To be certain the unit will not be damaged in shipment, observe the following rules:

- ① The packing carton must be strong enough for the item shipped.
- ② Make certain there are at least two inches of packing material between any point on the apparatus and the inside walls of the carton.
- ③ Make certain that the packing material cannot shift in the box or become compressed, allowing the instrument come in contact with the packing carton.

Address: PASCO scientific
10101 Foothills Blvd.
Roseville, CA 95747-7100

Phone: (916) 786-3800
FAX: (916) 786-3292
email: techsupp@pasco.com
web: www.pasco.com

Introduction

The PASCO Thermal Radiation System includes three items: the TD-8553 Radiation Sensor, the TD-8554A Radiation Cube (Leslie's Cube), and the TD-8555 Stefan-Boltzmann Lamp. This manual contains operating instructions for each of these items plus instructions and worksheets for the following four experiments:

- ① Introduction to Thermal Radiation,
- ② Inverse Square Law,
- ③ Stefan-Boltzmann Law* (at high temperatures),
- ④ Stefan-Boltzmann Law* (at low temperatures).

* The Stefan-Boltzmann law states that the radiant energy per unit area is proportional to the fourth power of the temperature of the radiating surface.

In addition to the equipment in the radiation system, several standard laboratory items, such as power supplies and meters are needed for most experiments. Check the experiment section of this manual for information on required equipment.

If you don't have all the items of the radiation system, read through the operating instructions for the equipment you do have, then check the experiment section to determine which of the experiments you can perform. (A radiation sensor is required for all the experiments.)

Radiation Sensor

The PASCO TD-8553 Radiation Sensor (Figure 1) measures the relative intensities of incident thermal radiation. The sensing element, a miniature thermopile, produces a voltage proportional to the intensity of the radiation. The spectral response of the thermopile is essentially flat in the infrared region (from 0.5 to 40 μm), and the voltages produced range from the microvolt range up to around 100 millivolts. (A good millivolt meter is sufficient for all the experiments described in this manual. See the current PASCO catalog for recommended meters.)

The Sensor can be hand held or mounted on its stand for more accurate positioning. A spring-clip shutter is opened and closed by sliding the shutter ring forward or back. During experiments, the shutter should be closed when measurements are not actively being taken. This helps reduce temperature shifts in the thermopile reference junction which can cause the sensor response to drift.

► **NOTE:** When opening and closing the shutter, it is possible you may inadvertently change the sensor position. Therefore, for experiments in which the sensor position is critical, such as Experiment 3, two small sheets of opaque insulating foam have been provided. Place this heat shield in front of the sensor when measurements are not actively being taken.

The two posts extending from the front end of the Sensor protect the thermopile and also provide a reference for positioning the sensor a repeatable distance from a radiation source.

Specifications

Temperature Range: -65 to 85 $^{\circ}\text{C}$.
 Maximum Incident Power: 0.1 Watts/ cm^2 .
 Spectral Response: $.6$ to $30\mu\text{m}$.
 Signal Output: Linear from 10^{-6} to 10^{-1} Watts/ cm^2 .

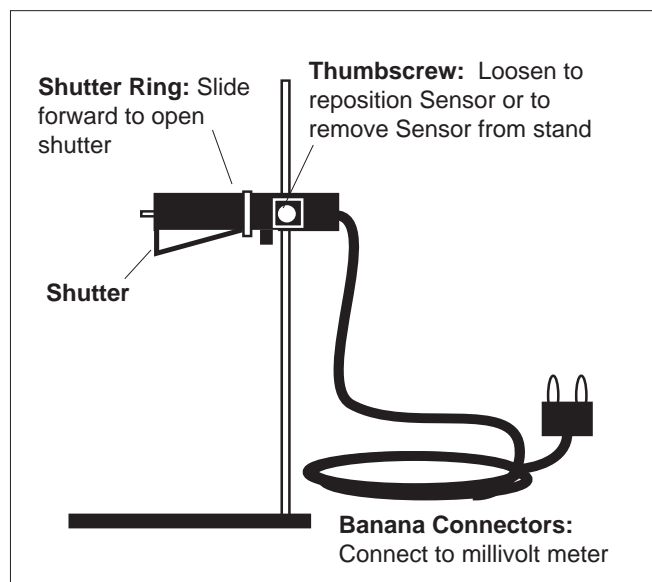

Figure 1 Radiation Sensor

Thermal Radiation Cube (Leslie's Cube)

The TD-8554A Radiation Cube (Figure 2) provides four different radiating surfaces that can be heated from room temperature to approximately 120 °C. The cube is heated by a 100 watt light bulb. Just plug in the power cord, flip the toggle switch to "ON", then turn the knob clockwise to vary the power.

Measure the cube temperature by plugging your ohmmeter into the banana plug connectors labeled THERMISTOR. The thermistor is embedded in one corner of the cube. Measure the resistance, then use Table 1, below, to translate the resistance reading into a temperature measurement. An abbreviated version of this table is printed on the base of the Radiation Cube.

► **NOTE:** For best results, a digital ohmmeter should be used. (See the current PASCO catalog for recommended meters.)

► **IMPORTANT:** When replacing the light bulb, use a 100-Watt bulb. Bulbs of higher power could damage the cube.

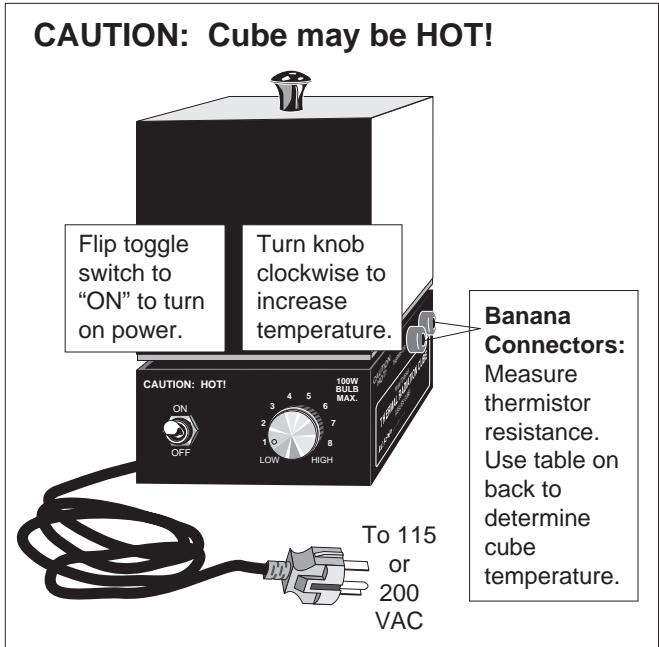

Figure 2 Radiation Cube (Leslie's Cube)

Table 1

Resistance versus Temperature for the Thermal Radiation Cube

Therm. Res. (Ω)	Temp. (°C)	Therm. Res. (Ω)	Temp. (°C)	Therm. Res. (Ω)	Temp. (°C)	Therm. Res. (Ω)	Temp. (°C)	Therm. Res. (Ω)	Temp. (°C)	Therm. Res. (Ω)	Temp. (°C)
207,850	10	66,356	34	24,415	58	10,110	82	4,615.1	106	2,281.0	130
197,560	11	63,480	35	23,483	59	9,767.2	83	4,475.0	107	2,218.3	131
187,840	12	60,743	36	22,590	60	9,437.7	84	4,339.7	108	2,157.6	132
178,650	13	58,138	37	21,736	61	9,120.8	85	4,209.1	109	2,098.7	133
169,950	14	55,658	38	20,919	62	8,816.0	86	4,082.9	110	2,041.7	134
161,730	15	53,297	39	20,136	63	8,522.7	87	3,961.1	111	1,986.4	135
153,950	16	51,048	40	19,386	64	8,240.6	88	3,843.4	112	1,932.8	136
146,580	17	48,905	41	18,668	65	7,969.1	89	3,729.7	113	1,880.9	137
139,610	18	46,863	42	17,980	66	7,707.7	90	3,619.8	114	1,830.5	138
133,000	19	44,917	43	17,321	67	7,456.2	91	3,513.6	115	1,781.7	139
126,740	20	43,062	44	16,689	68	7,214.0	92	3,411.0	116	1,734.3	140
120,810	21	41,292	45	16,083	69	6,980.6	93	3,311.8	117	1,688.4	141
115,190	22	39,605	46	15,502	70	6,755.9	94	3,215.8	118	1,643.9	142
109,850	23	37,995	47	14,945	71	6,539.4	95	3,123.0	119	1,600.6	143
104,800	24	36,458	48	14,410	72	6,330.8	96	3,033.3	120	1,558.7	144
100,000	25	34,991	49	13,897	73	6,129.8	97	2,946.5	121	1,518.0	145
95,447	26	33,591	50	13,405	74	5,936.1	98	2,862.5	122	1,478.6	146
91,126	27	32,253	51	12,932	75	5,749.3	99	2,781.3	123	1,440.2	147
87,022	28	30,976	52	12,479	76	5,569.3	100	2,702.7	124	1,403.0	148
83,124	29	29,756	53	12,043	77	5,395.6	101	2,626.6	125	1,366.9	149
79,422	30	28,590	54	11,625	78	5,228.1	102	2,553.0	126	1,331.9	150
75,903	31	27,475	55	11,223	79	5,066.6	103	2,481.7	127		
72,560	32	26,409	56	10,837	80	4,910.7	104	2,412.6	128		
69,380	33	25,390	57	10,467	81	4,760.3	105	2,345.8	129		

Stefan-Boltzmann Lamp

IMPORTANT: The voltage into the lamp should **NEVER exceed 13 V**. Higher voltages will burn out the filament.

The TD-8555 Stefan-Boltzmann Lamp (Figure 3) is a high temperature source of thermal radiation. The lamp can be used for high temperature investigations of the Stefan-Boltzmann Law. The high temperature simplifies the analysis because the fourth power of the ambient temperature is negligibly small compared to the fourth power of the high temperature of the lamp filament (see Experiments 3 and 4). When properly oriented, the filament also provides a good approximation to a point source of thermal radiation. It therefore works well for investigations into the inverse square law.

By adjusting the power into the lamp (13 Volts max, 2 A min, 3 A max), filament temperatures up to approximately 3,000 °C can be obtained. The filament temperature is determined by carefully measuring the voltage and current into the lamp. The voltage divided by the current gives the resistance of the filament.

Equipment Recommended

AC/DC LV Power Supply (SF-9584) or equivalent capable of 13 V @ 3 A max

$$T = \frac{R - R_{\text{ref}}}{\alpha R_{\text{ref}}} + T_{\text{ref}}$$

For small temperature changes, the temperature of the tungsten filament can be calculated using α , the temperature coefficient of resistivity for the filament:

where,

T = Temperature

R = Resistance at temperature T

T_{ref} = Reference temperature (usually room temp.)

R_{ref} = Resistance at temperature T_{ref}

α = Temperature coefficient of resistivity for the filament ($\alpha = 4.5 \times 10^{-3} \text{ K}^{-1}$ for tungsten)

For large temperature differences, however, α is not constant and the above equation is not accurate.

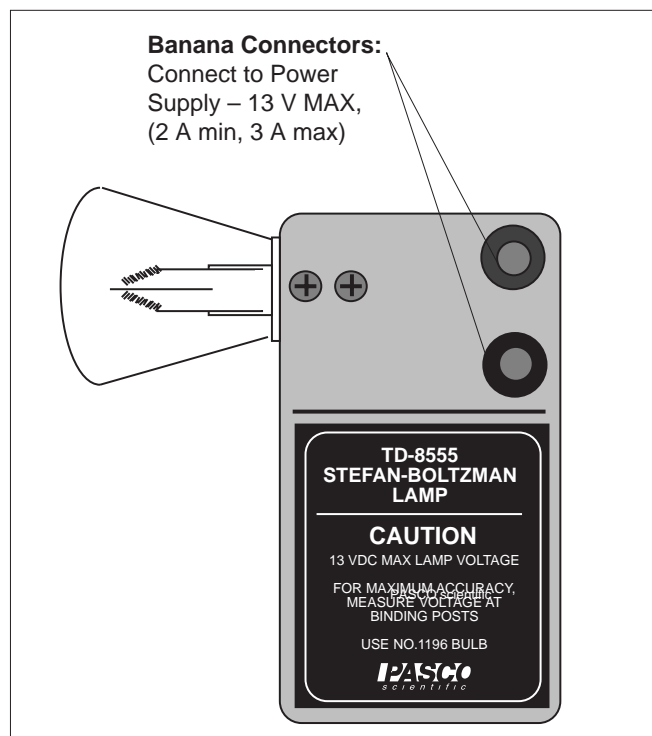

Figure 3 Stefan-Boltzmann Lamp

REPLACEMENT BULB: GE Lamp No. 1196, available at most auto parts stores.

► **NOTE:** When replacing the bulb, the leads should be soldered to minimize resistance.

For large temperature differences, therefore, determine the temperature of the tungsten filament as follows:

- ① Accurately measure the resistance (R_{ref}) of the tungsten filament at room temperature (about 300 °K). Accuracy is important here. A small error in R_{ref} will result in a large error in your result for the filament temperature.
- ② When the filament is hot, measure the voltage and current into the filament and divide the voltage by the current to measure the resistance (R_T).
- ③ Divide R_T by R_{ref} to obtain the relative resistance (R_T/R_{ref}).
- ④ Using your measured value for the relative resistivity of the filament at temperature T , use Table 2 on the following page, or the associated graph, to determine the temperature of the filament.

Table 2 Temperature and Resistivity for Tungsten

R/R _{300K}	Temp °K	Resistivity μΩ cm	R/R _{300K}	Temp °K	Resistivity μΩ cm	R/R _{300K}	Temp °K	Resistivity μΩ cm	R/R _{300K}	Temp °K	Resistivity μΩ cm
1.0	300	5.65	5.48	1200	30.98	10.63	2100	60.06	16.29	3000	92.04
1.43	400	8.06	6.03	1300	34.08	11.24	2200	63.48	16.95	3100	95.76
1.87	500	10.56	6.58	1400	37.19	11.84	2300	66.91	17.62	3200	99.54
2.34	600	13.23	7.14	1500	40.36	12.46	2400	70.39	18.28	3300	103.3
2.85	700	16.09	7.71	1600	43.55	13.08	2500	73.91	18.97	3400	107.2
3.36	800	19.00	8.28	1700	46.78	13.72	2600	77.49	19.66	3500	111.1
3.88	900	21.94	8.86	1800	50.05	14.34	2700	81.04	26.35	3600	115.0
4.41	1000	24.93	9.44	1900	53.35	14.99	2800	84.70			
4.95	1100	27.94	10.03	2000	56.67	15.63	2900	88.33			

Temperature versus Resistivity for Tungsten

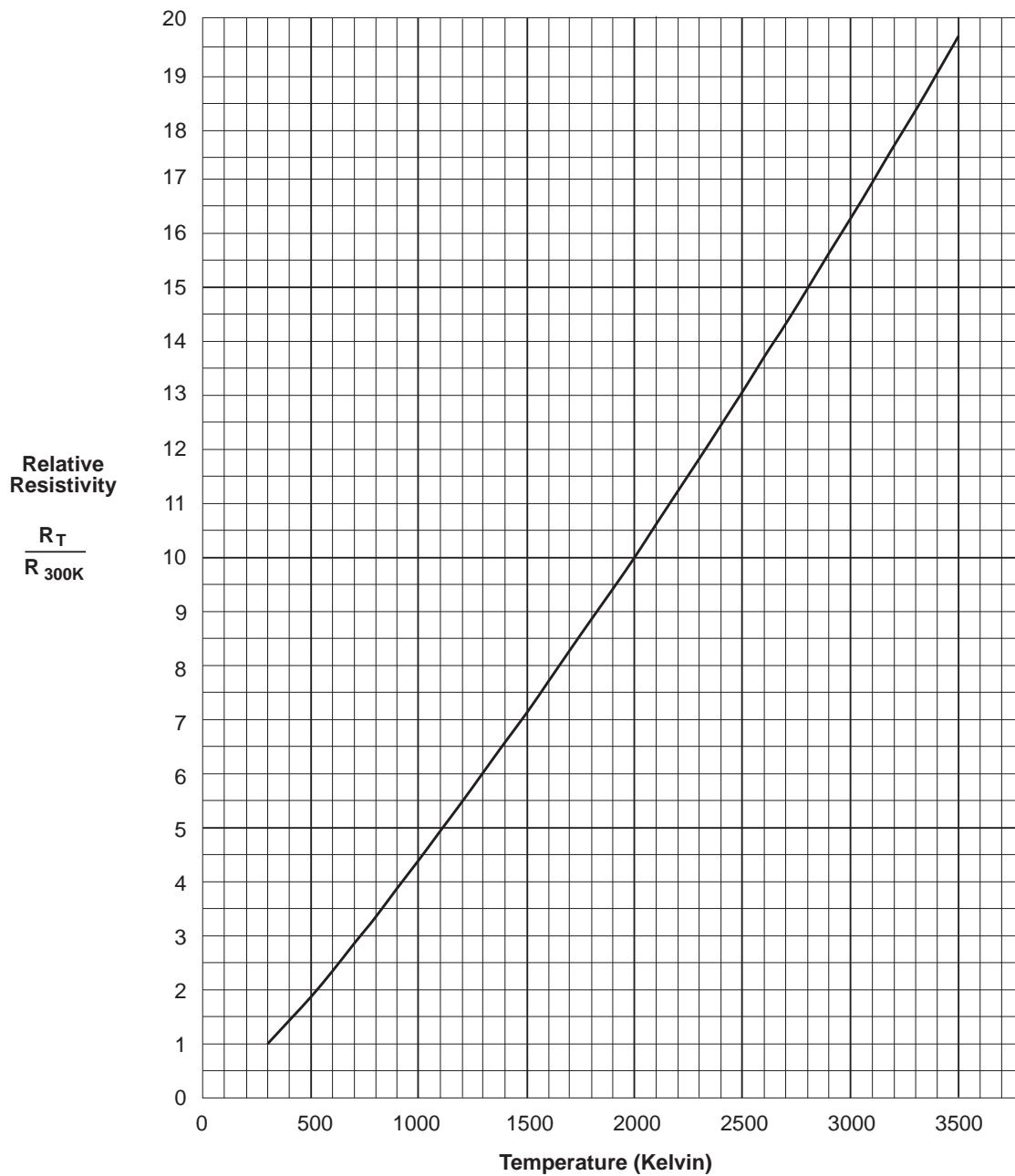

Experiment 1: Introduction to Thermal Radiation

EQUIPMENT NEEDED:

- Radiation Sensor, Thermal Radiation Cube
- Window glass
- Millivoltmeter
- Ohmmeter.

► NOTES:

- ① If lab time is short, it's helpful to preheat the cube at a setting of 5.0 for 20 minutes before the laboratory period begins. (A very quick method is to preheat the cube at full power for 45 minutes, then use a small fan to reduce the temperature quickly as you lower the power input. Just be sure that equilibrium is attained with the fan off.)
- ② Part 1 and 2 of this experiment can be performed simultaneously. Make the measurements in Part 2 while waiting for the Radiation Cube to reach thermal equilibrium at each of the settings in Part 1.
- ③ When using the Radiation Sensor, always shield it from the hot object except for the few seconds it takes to actually make the measurement. This prevents heating of the thermopile which will change the reference temperature and alter the reading.

Radiation Rates from Different Surfaces

Part 1

- ① Connect the Ohmmeter and Millivoltmeter as shown in Figure 1.1.
- ② Turn on the Thermal Radiation Cube and set the power switch to “HIGH”. Keep an eye on the ohmmeter reading. When it gets down to about 40 k Ω , reset the power switch to 5.0. (If the cube is preheated, just set the switch to 5.0.)
- ③ When the cube reaches thermal equilibrium—the ohmmeter reading will fluctuate around a relatively fixed value—use the Radiation Sensor to measure the radiation emitted from each of the four surfaces of the cube. Place the Sensor so that the posts on its end are in contact with the cube surface (this ensures that the distance of the measurement is the same for all surfaces). Record your measurements in the appropriate table on the following page. Also measure and record the resistance of the thermistor. Use the table on the base of the cube to determine the corresponding temperature.
- ④ Increase the power switch setting, first to 6.5, then to 8.0, then to “HIGH”. At each setting, wait for the cube to reach thermal equilibrium, then repeat the measurements of step 1 and record your results in the appropriate table.

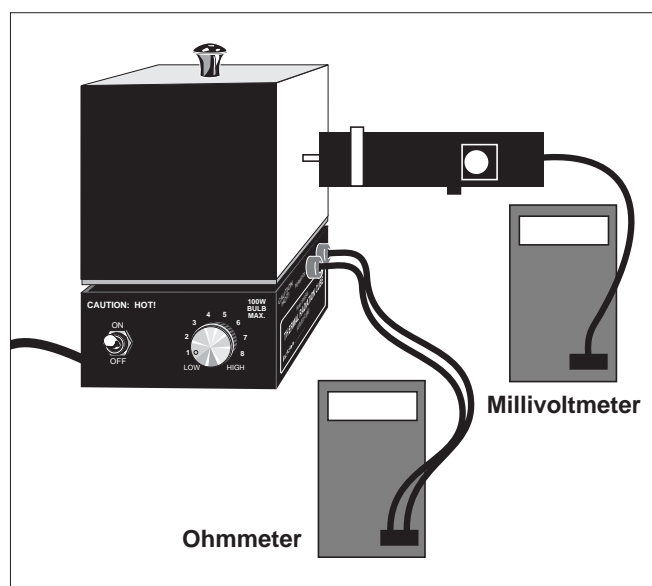

Figure 1.1 Equipment Setup

Part 2

Use the Radiation Sensor to examine the relative magnitudes of the radiation emitted from various objects around the room. On a separate sheet of paper, make a table summarizing your observations. Make measurements that will help you to answer the questions listed below.

Absorption and Transmission of Thermal Radiation

- ① Place the Sensor approximately 5 cm from the black surface of the Radiation Cube and record the reading. Place a piece of window glass between the Sensor and the bulb. Does window glass effectively block thermal radiation?
- ② Remove the lid from the Radiation Cube (or use the Stefan-Boltzmann Lamp) and repeat the measurements of step 1, but using the bare bulb instead of the black surface. Repeat with other materials.

Radiation Rates from Different Surfaces

Data and Calculations

Power Setting 5.0

Therm. Res. _____ Ω
 Temperature _____ $^{\circ}\text{C}$

Surface	Sensor Reading (mV)
Black	
White	
Polished Aluminum	
Dull Aluminum	

Power Setting 6.5

Therm. Res. _____ Ω
 Temperature _____ $^{\circ}\text{C}$

Surface	Sensor Reading (mV)
Black	
White	
Polished Aluminum	
Dull Aluminum	

Power Setting 8.0

Therm. Res. _____ Ω
 Temperature _____ $^{\circ}\text{C}$

Surface	Sensor Reading (mV)
Black	
White	
Polished Aluminum	
Dull Aluminum	

Power Setting 10.0

Therm. Res. _____ Ω
 Temperature _____ $^{\circ}\text{C}$

Surface	Sensor Reading (mV)
Black	
White	
Polished Aluminum	
Dull Aluminum	

Questions (Part 1)

- ① List the surfaces of the Radiation Cube in order of the amount of radiation emitted. Is the order independent of temperature?
- ② It is a general rule that good absorbers of radiation are also good emitters. Are your measurements consistent with this rule? Explain.

Questions (Part 2)

- ① Do different objects, at approximately the same temperature, emit different amounts of radiation?
- ② Can you find materials in your room that block thermal radiation? Can you find materials that don't block thermal radiation? (For example, do your clothes effectively block the thermal radiation emitted from your body?)

Absorption and Transmission of Thermal Radiation**Questions**

- ① What do your results suggest about the phenomenon of heat loss through windows?
- ② What do your results suggest about the Greenhouse Effect?

Notes

Experiment 2: Inverse Square Law

EQUIPMENT NEEDED:

- Radiation Sensor
- Stefan-Boltzmann Lamp, Millivoltmeter
- Power Supply (12 VDC; 3 A), meter stick.

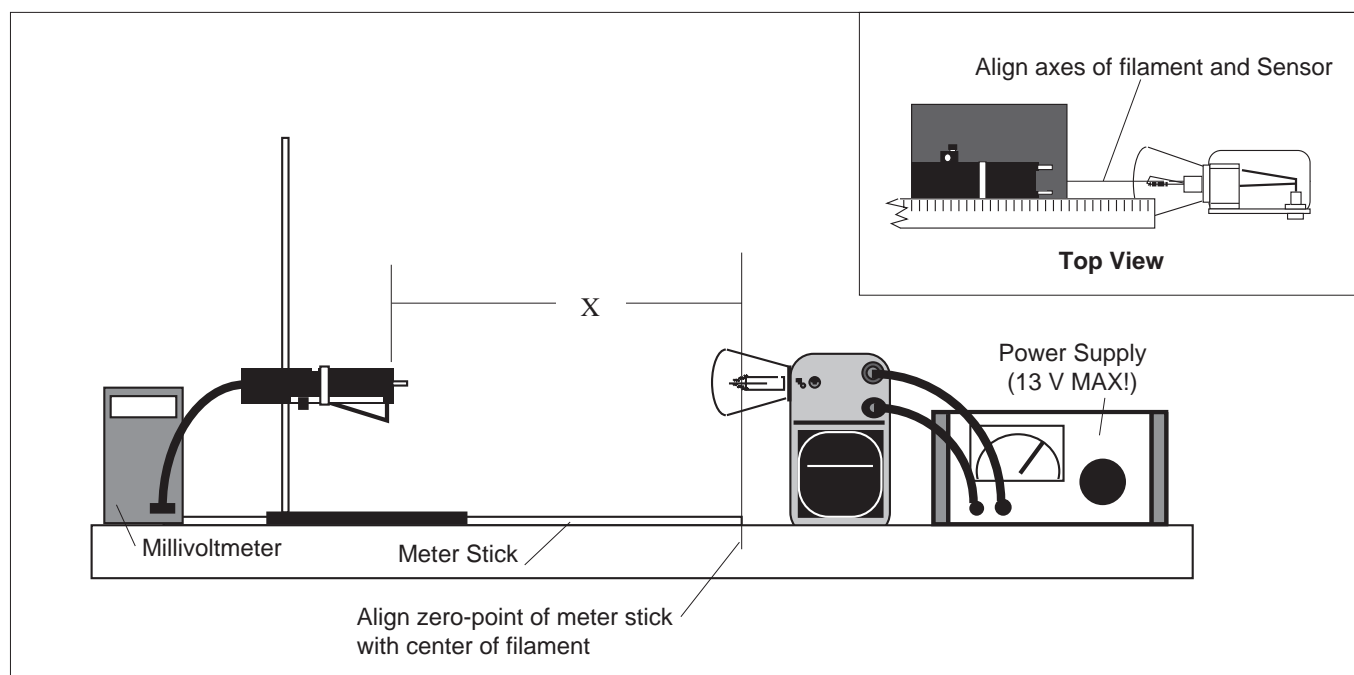

Figure 2.1 Equipment Setup

- ① Set up the equipment as shown in Figure 2.1.
 - a. Tape a meter stick to the table.
 - b. Place the Stefan-Boltzmann Lamp at one end of the meter stick as shown. The zero-point of the meter stick should align with the center of the lamp filament.
 - c. Adjust the height of the Radiation Sensor so it is at the same level as the filament of the Stefan-Boltzmann Lamp.
 - d. Align the lamp and sensor so that, as you slide the Sensor along the meter stick, the axis of the lamp aligns as closely as possible with the axis of the Sensor.
 - e. Connect the Sensor to the millivoltmeter and the lamp to the power supply as indicated in the figure.
- ② With the lamp OFF, slide the sensor along the meter stick. Record the reading of the millivolt-meter at 10 cm intervals. Record your values in Table 2.1 on the following page. Average these values to determine the ambient level of thermal radiation. You will need to subtract this average ambient value from your measurements with the lamp on, in order to determine the contribution from the lamp alone.
- ③ Turn on the power supply to illuminate the lamp. Set the voltage to approximately 10 V.

► **IMPORTANT:** Do not let the voltage to the lamp exceed 13 V.

- ④ Adjust the distance between the Sensor and the lamp to each of the settings listed in Table 2.2. At each setting, record the reading on the millivoltmeter.

► **IMPORTANT:** Make each reading quickly. Between readings, move the Sensor away from the lamp, or place the reflective heat shield between the lamp and the Sensor, so that the temperature of the Sensor stays relatively constant.

X (cm)	Ambient Radiation Level (mV)
10	
20	
30	
40	
50	
60	
70	
80	
90	
100	
Average Ambient Radiation Level =	

**Table 2.1
Ambient Radiation Level**

X (cm)	Rad (mV)	1/X ² (cm ⁻²)	Rad - Ambient (mV)
2.5			
3.0			
3.5			
4.0			
4.5			
5.0			
6.0			
7.0			
8.0			
9.0			
10.0			
12.0			
14.0			
16.0			
18.0			
20.0			
25.0			
30.0			
35.0			
40.0			
45.0			
50.0			
60.0			
70.0			
80.0			
90.0			
100.0			

**Table 2.2
Radiation Level versus Distance**

Calculations

- ① For each value of X , calculate $1/X^2$. Enter your results in Table 2.2.
- ② Subtract the Average Ambient Radiation Level from each of your Rad measurements in Table 2.2. Enter your results in the table.
- ③ On a separate sheet of paper, make a graph of Radiation Level versus Distance from Source, using columns one and four from Table 2.2. Let the radiation level be the dependent (y) axis.
- ④ If your graph from part 3 is not linear, make a graph of Radiation Level versus $1/X^2$, using columns three and four from table 2.2.

Questions

- ① Which of the two graphs is more linear? Is it linear over the entire range of measurements?
- ② The inverse square law states that the radiant energy per unit area emitted by a point source of radiation decreases as the square of the distance from the source to the point of detection. Does your data support this assertion?
- ③ Is the Stefan-Boltzmann Lamp truly a point source of radiation? If not, how might this affect your results? Do you see such an effect in the data you have taken?

Notes

Experiment 3: Stefan-Boltzmann Law (high temperature)

EQUIPMENT NEEDED:

- | | |
|----------------------|-------------------------|
| — Radiation Sensor | — Stefan-Boltzmann Lamp |
| — Ohmmeter | — Ammeter (0-3 A) |
| — Voltmeter (0-12 V) | — Millivoltmeter |
| — Ohmmeter | — Thermometer. |

Introduction

The Stefan-Boltzmann Law relates R , the power per unit area radiated by an object, to T , the absolute temperature of the object. The equation is:

$$R = \sigma T^4; \left(\sigma = 5.6703 \times 10^{-8} \frac{W}{m^2 K^4} \right)$$

In this experiment, you will make relative measurements of the power per unit area emitted from a hot object, namely the Stefan-Boltzmann Lamp, at various temperatures. From your data you will be able to test whether the radiated power is really proportional to the fourth power of the temperature.

Most of the thermal energy emitted by the lamp comes from the filament of the lamp. The filament temperature can be determined using the procedure given on pages 3 and 4 of this manual.

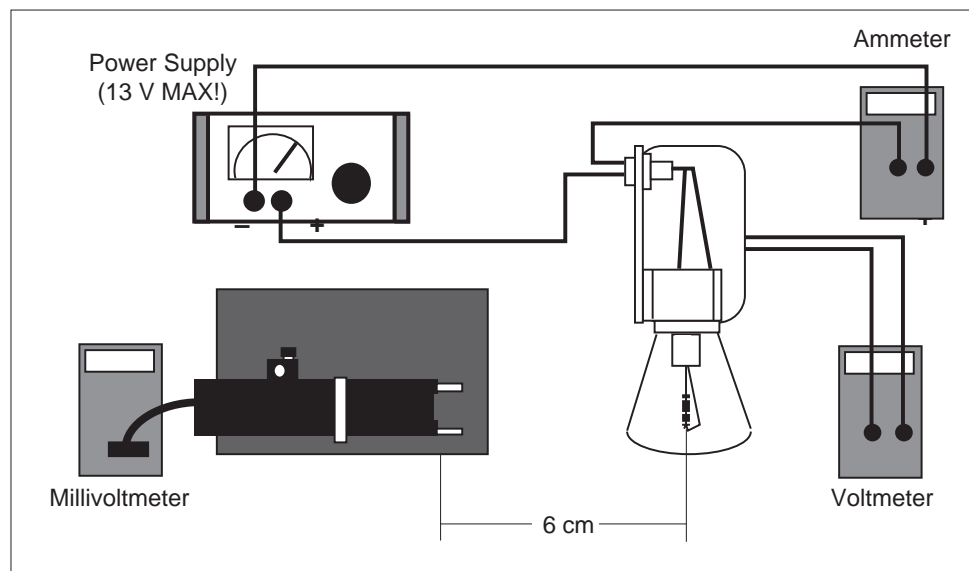

Figure 3.1 Equipment Setup

Procedure

► **IMPORTANT:** The voltage into the lamp should NEVER exceed 13 V. Higher voltages will burn out the filament.

- ① **BEFORE TURNING ON THE LAMP**, measure T_{ref} , the room temperature in degrees Kelvin, ($K = ^\circ\text{C} + 273$) and R_{ref} , the resistance of the filament of the Stefan-Boltzmann Lamp at room temperature. Enter your results in the spaces on the following page.
- ② Set up the equipment as shown in Figure 3.1. The voltmeter should be connected directly to the binding posts of the Stefan-Boltzmann Lamp. The Sensor should be at the same height as the filament, with the front face of the Sensor approximately 6 cm away from the filament. The entrance angle of the thermopile should include no close objects other than the lamp.
- ③ Turn on the power supply. Set the voltage, V , to each of the settings listed in Table 3.1 on the following page. At each voltage setting, record I , the ammeter reading, and Rad , the reading on the millivoltmeter.

► **IMPORTANT:** Make each Sensor reading quickly. Between readings, place both sheets of insulating foam between the lamp and the Sensor, with the silvered surface facing the lamp, so that the temperature of the Sensor stays relatively constant.

Data and Calculations

- ① Calculate R, the resistance of the filament at each of the voltage settings used ($R = V/I$). Enter your results in Table 3.1.
- ② Use the procedure on pages 3 and 4 of this manual to determine T, the temperature of the lamp filament at each voltage setting. Enter your results in the table.
- ③* Calculate T^4 for each value of T and enter your results in the table.
- ④* On a separate sheet of paper, construct a graph of Rad versus T^4 . Use Rad as your dependent variable (y-axis).

*In place of calculations ① and ③, some may prefer to perform a power regression on Rad versus T to determine their relationship, or graph on log-log paper and find the slope.

Questions

- ① What is the relationship between Rad and T? Does this relationship hold over the entire range of measurements?
- ② The Stefan-Boltzmann Law is perfectly true only for ideal, black body radiation. A black body is any object that absorbs all the radiation that strikes it. Is the filament of the lamp a true black body?
- ③ What sources of thermal radiation, other than the lamp filament, might have influenced your measurements? What affect would you expect these sources to have on your results?

$$\alpha = 4.5 \times 10^{-3} \text{ K}^{-1}$$

$$T_{\text{ref}} \text{ (room temperature)} = \text{_____ K} \quad (\text{K} = \text{°C} + 273)$$

$$R_{\text{ref}} \text{ (filament resistance at } T_{\text{ref}}) = \text{_____ } \Omega$$

Table 3.1

Data			Calculations		
V (Volts)	I (Amps)	Rad (mV)	R (Ohms)	T (K)	T^4 (K^4)
1.00					
2.00					
3.00					
4.00					
5.00					
6.00					
7.00					
8.00					
9.00					
10.00					
11.00					
12.00					

Notes

Experiment 4: Stefan-Boltzmann Law (low temperature)

EQUIPMENT NEEDED:

- | | |
|--------------------|--------------------------|
| — Radiation Sensor | — Thermal Radiation Cube |
| — Millivoltmeter | — Ohmmeter. |

Introduction

In experiment 3, you investigated the Stefan-Boltzmann Law ($R_{\text{rad}} = sT^4$) for the high temperatures attained by an incandescent filament. At those high temperatures (approximately 1,000 to 3,000 K), the ambient temperature is small enough that it can be neglected in the analysis. In this experiment you will investigate the Stefan-Boltzmann relationship at much lower temperatures using the Thermal Radiation Cube. At these lower temperatures, the ambient temperature can not be ignored.

If the detector in the Radiation Sensor were operating at absolute zero temperature, it would produce a voltage directly proportional to the intensity of the radiation that strikes it. However, the detector is not at absolute zero temperature so it is also radiating thermal energy.

According to the Stefan-Boltzmann law, it radiates at a rate, $R_{\text{det}} = sT_{\text{det}}^4$. The voltage produced by the sensor is proportional to the radiation striking the detector minus the radiation leaving it. Mathematically, the sensor voltage is proportional to $R_{\text{net}} = R_{\text{rad}} - R_{\text{det}} = s(T^4 - T_{\text{det}}^4)$. As long as you are careful to shield the Radiation Sensor from the Radiation Cube when measurements are not being taken, T_{det} will be very close to room temperature (T_{rm}).

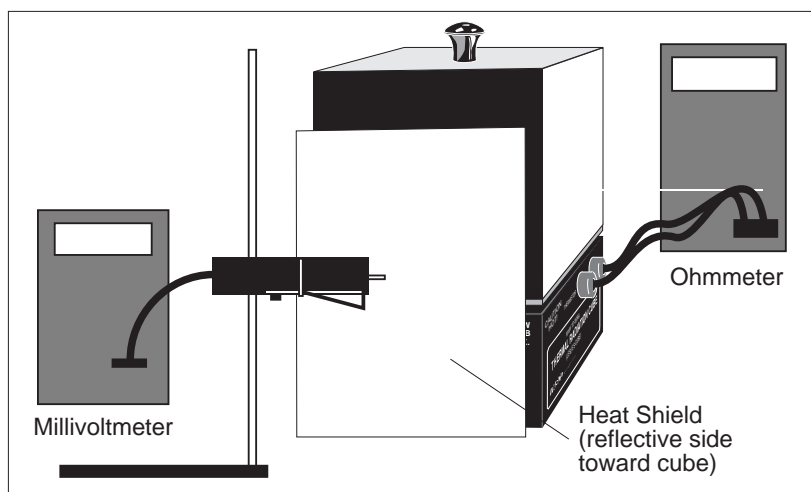

Figure 4.1 Equipment Setup

Procedure

- ① Set up the equipment as shown in Figure 4.1. The Radiation Sensor should be pointed directly at the center of one of the better radiating surfaces of the cube (the black or white surface). The face of the Sensor should be parallel with the surface of the cube and about 3 to 4 cm away.
- ② With the Thermal Radiation Cube off, measure R_{rm} , the resistance of the thermistor at room temperature. Enter this data in the space on the following page.
- ③ Shield the sensor from the cube using the reflecting heat shield, with the reflective side of the shield facing the cube.
- ④ Turn on the Radiation Cube and set the power switch to 10.
- ⑤ When the thermistor resistance indicates that the temperature is about 12 C° above room temperature, turn the power down so the temperature is changing slowly. Read and record R , the ohmmeter reading, and R_{ad} , the millivoltmeter reading. The readings should be taken as nearly simultaneously as possible while briefly removing the heat shield. Record these values in Table 4.1.

► **IMPORTANT:** Make each reading quickly, removing the heat shield only as long as it takes to make the measurement. Take care that the position of the sensor with respect to the cube is the same for all measurements.

- ⑥ Replace the heat shield, and turn the cube power to 10. When the temperature has risen an additional 12-15 C°, repeat the measurements of step 5. Repeat this procedure at about 12-15° intervals until the maximum temperature of the cube is reached.

Data and Calculations

Room Temperature: $R_m = \text{_____ } \Omega$

$T_m = \text{_____ } ^\circ\text{C} = \text{_____ } \text{K}$

Table 4.1

Data			Calculations		
R (Ω)	Rad (mV)	T_c ($^\circ\text{C}$)	T_k (K)	T_k^4 (K^4)	$T_k^4 - T_m^4$ (K^4)

- ① Using the table on the base of the Thermal Radiation Cube, determine T_c , the temperature in degrees Centigrade corresponding to each of your thermistor resistance measurements. For each value of T_c , determine T_k , the corresponding value in degrees Kelvin ($\text{K} = ^\circ\text{C} + 273$). Enter both sets of values in Table 4.1, above. In the same manner, determine the room temperature, T_m .
- ② Calculate T_k^4 for each value of T_k and record the values in the table.
- ③ Calculate $T_k^4 - T_m^4$ for each value of T_k and record your results in the table.
- ④ On separate sheet of paper, construct a graph of Rad versus $T_k^4 - T_m^4$. Use Rad as the dependent variable (y-axis).

Questions

- ① What does your graph indicate about the Stefan-Boltzmann law at low temperatures?
- ② Is your graph a straight line? Discuss any deviations that exist.

Teacher's Guide

Experiment 1: Introduction to Thermal Radiation

Notes on Questions

Part 1

- ① In order of decreasing emissivity, the surfaces are Black, White, Dull Aluminum, and Polished Aluminum. This order is independent of temperature; and within the temperature range tested, the ratio of emissions between sides is almost constant. The normalized percentages are as follows: (Black is defined as 100%)

Surface	Normalized Emissions	Standard Error
Black	100	
White	96.86	±1.21%
Dull	20.23	±2.17%
Polished	7.38	±1.82%

- ② Measurements are consistent with the rule. The better reflectors (poorer absorbers) are poor emitters.

Notes on Questions

Part 2

- ① Yes. All sides of the Leslie's Cube are at the same temperature, but the polished side emits less than 10% as much radiation as the black side.
- ② Materials that block thermal radiation well include aluminum foil, styrofoam, etc. Materials that do not block radiation as well include air, clothing, etc. All materials will block radiation to some degree, but there are strong differences in how much is blocked.

Notes on Questions

Absorption and Transmission of Thermal Radiation

- ① Heat loss through (closed) windows is primarily conductive. Although the glass tested transmitted some infrared, most was blocked.
- ② A greenhouse allows light in, but does not allow much heat to escape. This phenomenon is used to grow tropical plants in cold climates.

Experiment 2: Inverse Square Law

Calculations

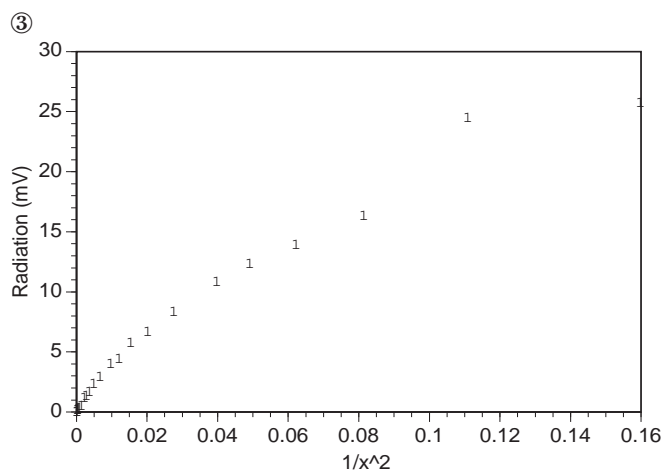
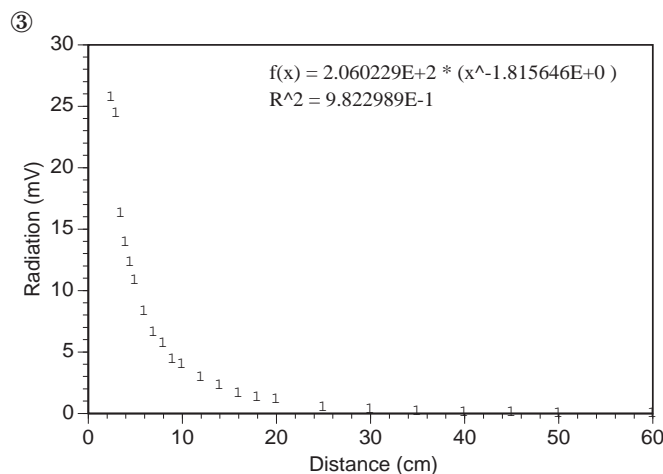

Notes on Questions

- ① The graph of Radiation versus $1/x^2$ is more linear, but not over the entire range. There is a distinct falloff in intensity at the nearer distances, due to the non-point characteristics of the lamp. (A graph of Radiation versus $1/x^2$ using only data points from 10cm or more is nearly linear.)
- ② If we use data from distances that are large compared to the size of the lamp filament—so that the filament is effectively a “point”—then this data supports the hypothesis.
- ③ The Stefan-Boltzmann Lamp is not truly a point source. If it were not, then there would be a falloff in light level for measurements taken close to the lamp. This falloff can be seen in our data.

Suggestion:

The largest part of the error in this lab is due to the non-point nature of the Stefan-Boltzmann Lamp. You can approximate a much better “point” source with a laser and a converging lens.

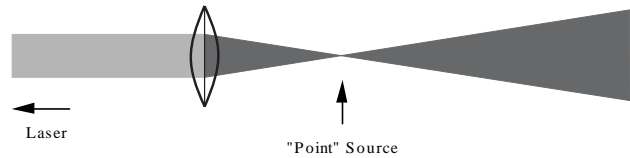

For best results, use a short-focal-length lens and make sure that the sensor is always completely within the beam.

Experiment 3: Stefan-Boltzmann Law (at high temperatures)

Notes on Procedure

Part 1

- ③ Between readings, place the insulating material between the lamp and the sensor. For best results use both sheets, with the aluminum sides facing away from each other. Remove the sheets for only enough time to take each measurement.

Calculations

③/④

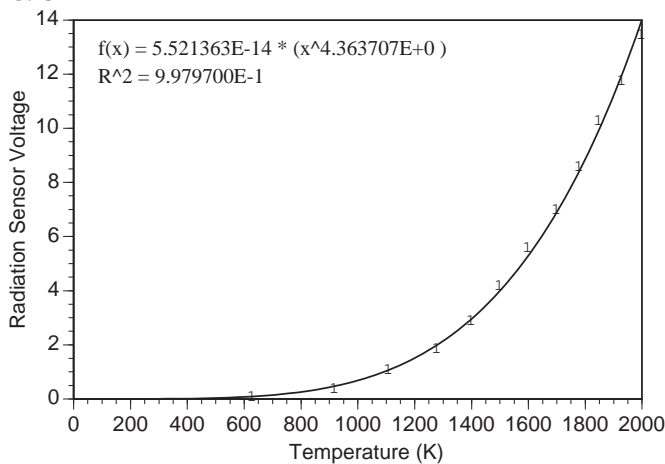

Notes on Questions

- ① A power regression of our data shows a power of 4.36. However, an analysis of only those points with temperature greater than 1500° shows a power of 4.01. This inaccuracy in the low-temperature points is due to absorption of the infrared by the glass lamp bulb. (See experiment 1) This absorption is more significant at the lower temperatures, where the infrared makes up a larger percentage of the entire output.

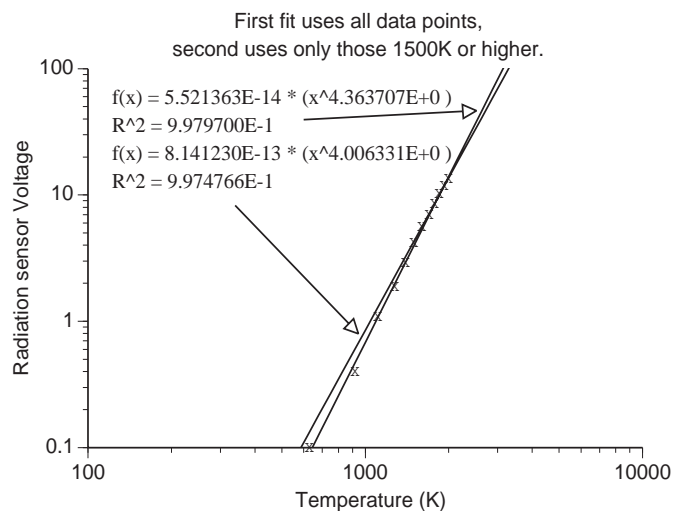

- ② The lamp filament is not a true black body. If it were, it would be completely and totally black at room temperature. It is a fairly good approximation, though, as long as the temperature is high enough that the emitted light is much greater than the incident light.
- ③ Any other thermal source in the room would influence the results, including the warm body of the experimenter and the room itself. These introduce some error, but it is small as long as the temperature of the lamp is high compared to the temperature of these other sources.

Experiment 4: Stefan-Boltzmann Law (at low temperatures)

Notes on Procedure

- ③ Make sure that the Thermal Radiation Cube has been off for enough time to be at equilibrium with the room before making this measurement. If the cube has been turned on recently, use another thermometer to make the measurement.
- ⑤ Use ridiculous precautions with this experiment. It is impossible to have too much insulation between the cube and the sensor between measurements. For our experiments, we use two foam sheets covered with aluminum tape, and an air gap between the sheets. We never removed this heat shield for more than 5 seconds while taking a measurement.

Calculations

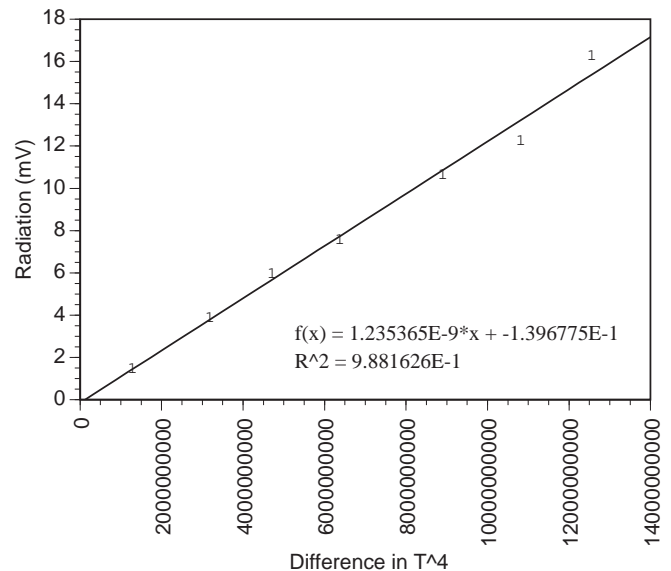

Notes on Questions

- ① The linearity of this graph indicates that the Stefan-Boltzmann equation is correct, even at low temperatures.
- ② The graph should be straight, with some statistical variations.

Notes

Technical Support

Feed-Back

If you have any comments about this product or this manual please let us know. If you have any suggestions on alternate experiments or find a problem in the manual please tell us. PASCO appreciates any customer feed-back. Your input helps us evaluate and improve our product.

To Reach PASCO

For Technical Support call us at 1-800-772-8700 (toll-free within the U.S.) or (916) 786-3800.

Contacting Technical Support

Before you call the PASCO Technical Support staff it would be helpful to prepare the following information:

- If your problem is computer/software related, note:

Title and Revision Date of software.

Type of Computer (Make, Model, Speed).

Type of external Cables/Peripherals.

- If your problem is with the PASCO apparatus, note:

Title and Model number (usually listed on the label).

Approximate age of apparatus.

A detailed description of the problem/sequence of events. (In case you can't call PASCO right away, you won't lose valuable data.)

If possible, have the apparatus within reach when calling. This makes descriptions of individual parts much easier.

- If your problem relates to the instruction manual, note:

Part number and Revision (listed by month and year on the front cover).

Have the manual at hand to discuss your questions.

